

Multi-Channel Configuration for improving received signal strength in non-line-of-sight environments of indoor visible light communication localization

Hilal A. Fadhil¹, Feras H. AlAttar², Tariq Adnan Fadil³, Haider J. Abd⁴

¹Electrical and Computer Dep. Faculty of Engineering, Sohar University, Sohar-Oman

²Electrical & communication Eng., National University of science and technology, Muscat-Oman

³Dep. Of computer Eng., Techniques, Dijlah University, Baghdad, IRAQ

⁴Electrical Eng. Department dept. University of Babylon, Babylon, IRAQ:

Article Info

Article history:

Received May 15, 2022

Revised Jun 18, 2022

Accepted Oct 24, 2022

Keyword:

VLC
LEC
LOS
BER

ABSTRACT

In modern engineering technologies, optical communications is major field of primary concern of telecommunication. A feature of Light-emitting diode (LED) light sources is the ability to send the light intensity over the data bits with high system performance and no extra cost. The VLC (Visible Light Communication) is gaining exclusive advantages over the wireless communication model, as it utilizes a technology by which light can be used to transmit data. It is commonly seen that dealing with non-line of sight (NLOS) is a major challenge for VLC systems as the light intensity is reflected in a variety of directions. To overcome this drawback, a new technique based on multichannel configuration is utilized to enhance the overall system performance. On the basis of the eye-diagram, bit error rate, and output signal, a VLC model is designed and simulated for indoor used and received power of the proposed system. We also investigated the model under the influence of lighting noises in the ambient environment. The corresponding results are compared with the conventional NLOS system and an inference made shows the significant improvement for the next-generation optical communication system.

Copyright © 2022 Institute of Advanced Engineering and Science.
All rights reserved.

Corresponding Author:

Hilal A. Fadhil,
Department of Electrical and Computer Engineering,
Sohar University,
Sohar-Oman
Email: hfadhil@su.edu.om

1. INTRODUCTION

It is possible to communicate wirelessly indoors with visible light communication (VLC) since LEDs can be used as transmitters. The LEDs are ideal transmitters for visible light communication since they are energy-efficient and can transmit both light and data. With a huge development of lighting technology, Gigabit range data can now be transmitted using optical fibers with low attenuation due to the rapid development of new fibers, the use of ultra high-speed optoelectronics LEDs and lasers has increased. Based on previously published articles, since 1987, the economic demand for lighting has increased by 67%, and it is expected to grow by 80% by 2030 [1]. As an example, a new report from Navigant Consulting, Inc. indicates that global LED sales will increase dramatically between now and 2024. Additional benefits of LED include higher transmission rate, tunable illumination, Compared to conventional lighting, this technology provides greater security, license-free use, an extended lifespan and a broad bandwidth. KAUST, King Abdullah University of Science and Technology (Saudi Arabia), has a research group working on high-speed, high bandwidth superluminescent diodes with a bandwidth exceeding 400 MHz [2-4] to increase transmitter capacity. Their study demonstrated a 3.2 Gb/s Virtual Linear Channel (VLC) link using 15 pairs of multiple quantum wells (MQW) based micro-photodetectors in indium gallium nitride (InGaN)/GaN. [6]. While, some team are

working on the transmission of multi-Gigabit data per LED light and overcoming the technical challenges of VLC optical receivers [3]. During the 'LIGHT & Building 2018' event in Germany, LED professionals from Sant'Anna School and TCI LED showed their object detection systems. The Institute of Telecommunication and Information Technologies [4-5] designed a photonics VLC system for an outdoor application based on LEDs optoelectronics devices and an optical wireless link [3-5].

Today, one of the major questions in optical communications is how to achieve effective NLOS networking. In an optical network, the recommended and cost-effective method for dealing with NLOS conditions is simply to circumvent the obstruction by placing relays at other locations. Some more advanced NLOS transmission schemes now use multipath signal propagation, bouncing the radio signal off other nearby objects to get to the receiver. Non-Line-of-Sight (NLOS) is a term often used in radio communications to describe a radio channel or link where there is no visual line of sight (LOS) between the transmitting antenna and the receiving antenna. LEDs are considered one of the most recommended solutions to achieve Gigabit (G-bit) VLC due to their high modulation bandwidth, but the industrial fabrication of μ LEDs is expensive and difficult [7]. The signal strength improvement of the VLC system utilizing the LEDs is considered to be a significant challenge especially for the indoor non-line-of-sight environment. In the current research, most researchers are concerned with developing the nanostructure layer and fabrication of LEDs in order to improve the total received power and minimize the loss of light intensity due to NLOS. It is considered to be costly to fabricate and develop new LEDs and further research is necessary. As a result, a new and cost-effective approach has been proposed to overcome the limitations of indoor NLOS through a multi-channel configuration. The multi-channel configuration is based on the improvement of the light intensity in NLOS environments. This paper is presented as follows. In section two, a brief review of LED based VLC technology used for the work is given. Section three focuses on the design methodology used to improve the NLOS model. Finally, section four and five list the various results obtained and the conclusions are presented.

2. A REVIEW OF LEDS BASED VLC TECHNOLOGY

There are two types of light source which is usually recommend in the VLC manufacturing the white color and yellow color the yellow phosphor-based illumination is consider less expensive, but it offers a long lifetime, and is obtainable everywhere in the market. However, Table 1 shows the LED types based on bandwidth of few MHz for VLC LOS and NLOS applications [4-7]. PC-LED [6] and RGB LEDs [8], and μ LED [9]. Several techniques have been explored in previously published articles to enhance the modulation bandwidth performance of LEDs; these include multilayer restructuring within quantum wells (QWs), varying the layer-width of LED active region or altering the RC structure [6-8].

Increasing the current density within the LED's active region is one technique to increase the carrier lifespan. A research group led by [4] generated a signal with a modulation bandwidth of 430 MHz inside a 25 m diameter active area of an LED to create a current flow density of 18.7 kA/cm². Another study group [5] established a new strategy to reduce electron lifespan and modulation frequency band of LED by introducing external strain around the MQW. The use of traditional vapor deposition techniques to create a hetero-structure can enhance the performance of nano-wire LEDs, allowing them to be modeled as core-shell device topologies [3-6]. Till 2016, a research group has created two prototypes, firstly, a 226 MHz based the blue emitting micro-LED with gallium-doped zinc oxide; and, secondly, a 244 MHz bandwidth was tested using GaN micro-LED arrays in [7]. Explaining research chronological, including research design, research procedure (in the form of algorithms, Pseudocode or other), how to test and data acquisition [1], [3]. The description of the course of research should be supported references, so the explanation can be accepted scientifically [2], [4].

| LED Types | Bandwidth | Performance | Application |
|------------------------------------|-------------|-------------|------------------------|
| organic light emitting diodes-NLOS | 1-5 MHz | Medium | All VLC type |
| phosphor-coated (PC) LED-LOS | 3-5 MHz | low | Indoor VLC-LOS |
| RGB LED-LOS | 15-35 MHz | High | Outdoor VLC(LOS+NLOS) |
| resonant cavity (RC) LEDs-LOS | ~ 100 MHz | High | Outdoor VLC (LOS+NLOS) |
| Micro-NLOS | 350-900 MHz | High | Sensing+ Indoor LOS |
| GaN nano-NLOS | ~ 1 GHz | High | Outdoor VLC LOS+NOLS |

Figure 1. LED Types

Several types of high-speed VLC links have been developed based on group III-nitride materials, including InGaN LEDs using different orientations on the c-plane. These conventional LEDs are oriented on a polar surface, but are limited in terms of quantum Confined Stark Effect (CSE) because of the high polarization field impacts. According to the previously published articles [1-7], most of the developed LED have been proposed in various ways, including metallic grating coated LEDs, flip-chip LEDs, chemical-etching surfaces, and surface roughening. Besides the photonic crystal, another approach is placed on the top layer as reported by [13], also [12] developed a new micro/nanostructure by modifying the GaN top layer.

3. SYSTEM DESIGN

3.1. Conventional VLC system

Figure 2 shows the designed block diagram of a VLC system. The system is provided with three major components, which are the transmitter, channel, and receiver, the transmitter part of which is used to send data signals through LEDs. By combining multiple solid state devices and uni-color emitters via color changing material, each source transmit a single wavelength of white light.

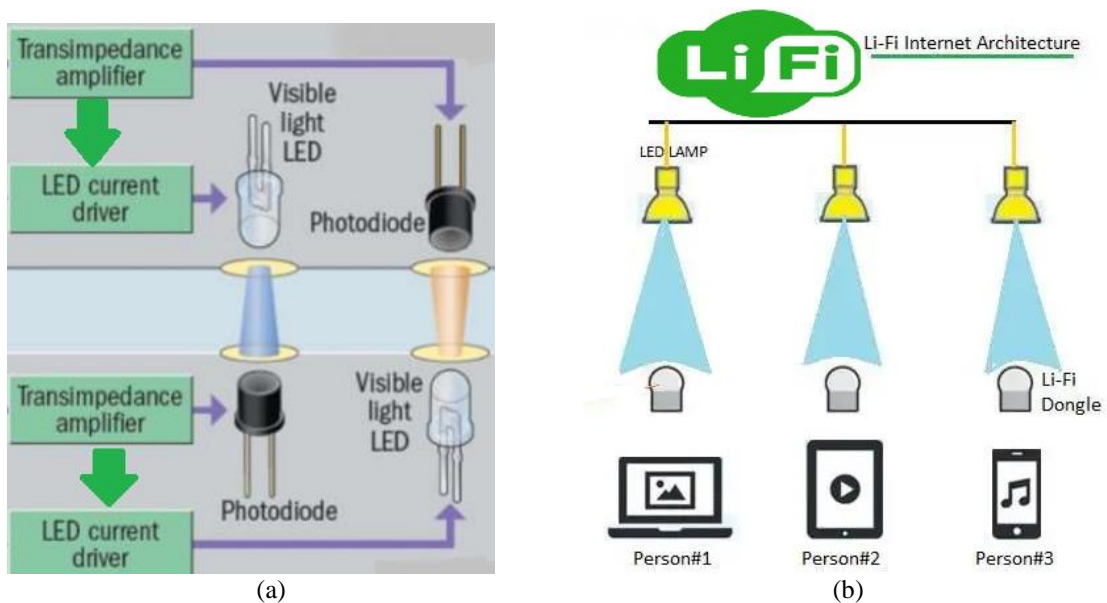

Figure 2. (a) VLC system block diagram ; (b) indoor VLC system implementation for Future LiFi System

The NLOS has been realized by adding one or more FSO over Multi-Mode Fiber (FSOoMMF) to VLC networks mitigates the NLoS reflection by collecting the NLOS signal via Router and then been on abstract and conclusion are revised. This can be explained by employing the idea that the second -Turn NLOS has multiple propagation paths along the various room corners from TX to RX, whereas the first-Turn NLOS has a single dominant propagation path from TX to RX. The Uniform Geometric Theory of Diffraction is applied to the development of a path loss model encompassing first- and second-turn NLOS links and separate scattering and diffraction parameters for the first and second corners, in consideration of this case. Further, we incorporate an adjustable "waveguide effect" parameter in order to take into account the effect of room heights on path loss. This implies that higher wall alleys are conducive to better propagation condition. The VLC model was modeled in Optisystem, and the expected results were over 400 Mbp. Using simplest modulation format of OOK based utilizing MZ modulator and PN sequences was designed as an input signal and generated the eyes diagram plot. Figure 3 shows the proposed simulation using optisystem software ver.15 from optiwaveTM, VLC channel is divided into two paths: Line of sight (LOS) and Non-light-of-sight (NLOS). The NLOS scenario is defined as the multi-reflection environment which increase the distance between the transmitter and receiver and decrease the transmission rate. For typical transmission of VLC system, maximum signal strength quality can be achieved in line of sight (LOS) condition, but the reflected light from surrounding walls for NLOS degrades the system link performance significantly. The receiver part convert the received optical signal back to electrical, which is then amplify with a rectangular optic filter and a photodiode. To remove the noise that is added to the system when traversing through a channel, a Bessel filter is applied, followed by an electrical amplifier, which exposes the original input signal.

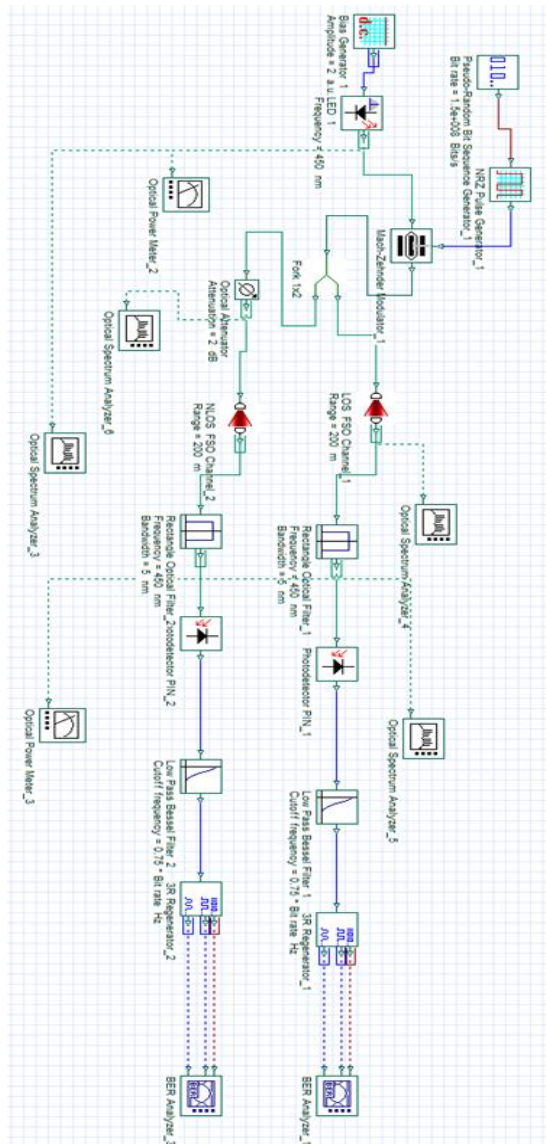

Figure 3. VLC Simulation model based LOS and NLOS conditions.

3.2. Multi-channel configuration

Based on the previously published articles VLC models have been designed based on LOS condition[11-14]. However, practical implementation of indoor VLC models must considered the NLOS as a result of some reflected light from different walls and the received optical signal-to—noise ratio (OSNR) strength will be decreased as the transmission distance is increased. Hence, this drawback of the NLOS condition with degraded the Bit-error rate (BER) performance. Figure 4 shows a new technique to overcome the power loss due to NLOS condition by using multi-channel configuration. Therefore, adding one or more FSO over Multi-Mode Fiber (FSOoMMF) to VLC networks mitigates the NLoS reflection by collecting the NLOS signal via Router and then re-transmit the signal again through RF network with high capacity (either RF or VLC). The reasons of using MMF because of short transmission distance (indoor environment) and the usage of LED light source applicable for MMF cable which improve the overall system's performance with the acceptable BER performance. The received optical power detected by PIN photo-detector is given as

$$P_{Sr} = \mathcal{R} P_o(t)H(t) \tag{1}$$

Where, R is the responsivity of the photo detector, $P_o(t)$ is the optical output power and $H(t)$ is channel transfer function.

While, the total noise associated with LOS and NLOS is given as

$$\langle \text{noise power} \rangle = \sigma_{\text{Thermal}}^2 + \sigma_{\text{shot}}^2 + \sigma_{\text{LOS}}^2 + \sigma_{\text{NLOS}}^2 \tag{2}$$

And the optical signal-to-noise (OSNR) is expressed as

$$\text{OSNR} = \frac{\langle \text{signal power (Psr)} \rangle}{\langle \text{Noise power} \rangle} \tag{3}$$

And the bit-error rate is calculated as

$$\text{BER} = Q\sqrt{\text{OSNR}} \tag{4}$$

Where, Q is the quality factor (Q)

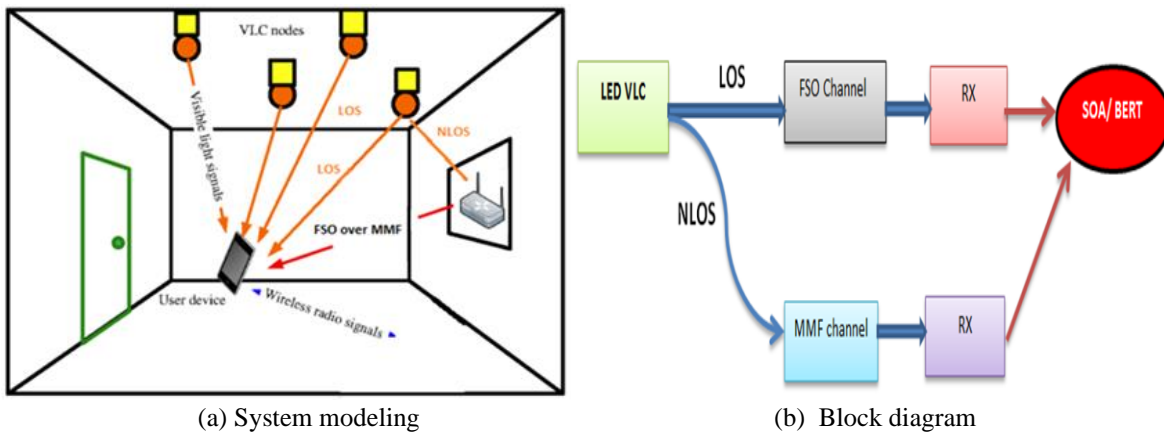

(a) System modeling (b) Block diagram
Figure 4. Proposed VLC model based multi-channel configuration

4. RESULTS AND DISCUSSION

A description of the RGB based downlink LEDs transmission has been provided as with the peak wavelengths of 469, 529, and 645 nm as the peak power levels, relative spectral outputs and beam profiles have been set for frequency response. A standard bandwidth at 1 MHz was normalized output power of 0 dBm. Therefore, the measured 3 dB bandwidths for the R, B, and G LED chips are 8.8, 7.6, and 7 MHz, respectively. With a slight overlap between the Blue and Green LED spectral profiles shown in Figure 5, the relative spectral profiles indicate adequate isolation between wavelengths.

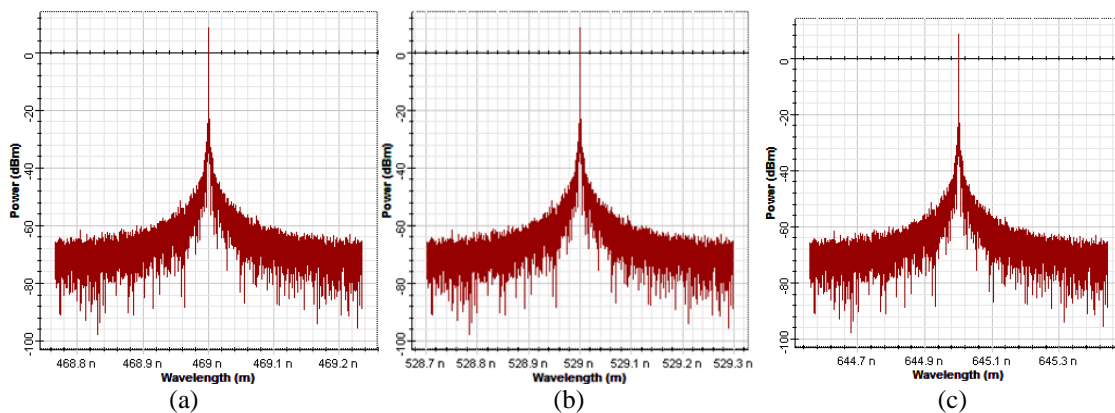

Figure 5. RGB LED normalized frequency response; (a)RED-LED at 469nm; (b)Green-LED at 529nm; (c) Blue-LED at 645nm

Figures 6–7 show the simulated results that have been analyzed the BER value as a function of transmission distance. It is seen that with the expanding transmission distance, minimum BER is increased for all LOS/NLOS condition. But the LOS path achieved better results compared with NLOS path.

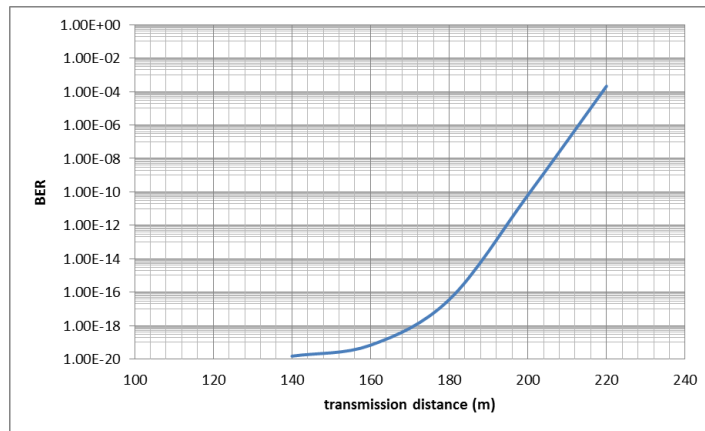

Figure 6. BER versus transmission distance of the proposed VLC system

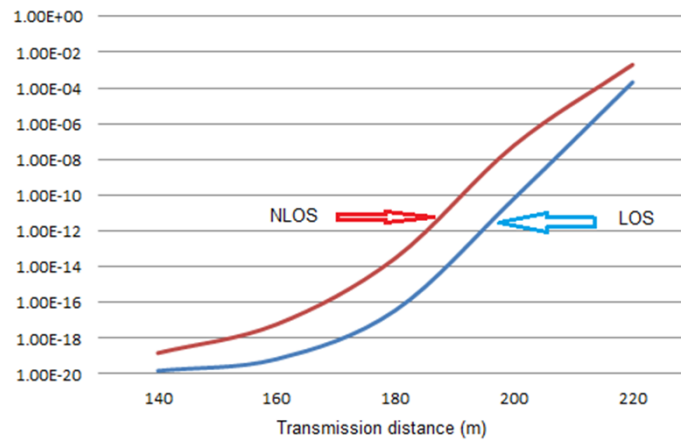

Figure 7. BER versus transmission distance of the proposed VLC system based on LOS/ NLOS environment

Changing the beam of divergence (BoD) concentrator angle was used to analyze the total received power performance at the receiver end. Beam divergence is an important factor for determining visible light range at the receiver. The larger BoV can increase the dominance of the direct LOS path. In Figure 8, the BoD was varied from 0.25° to 2° mrad to maintain the standard usable range. In this case, the receive power varied around ~ -13.8 to -28.74 dBm. Therefore, it is very important to adjust the BoD for good lighting and for achieving higher data rates over a VLC link. An important influence on BoD is gain, the received power, and the overall transmission rate of VLC.

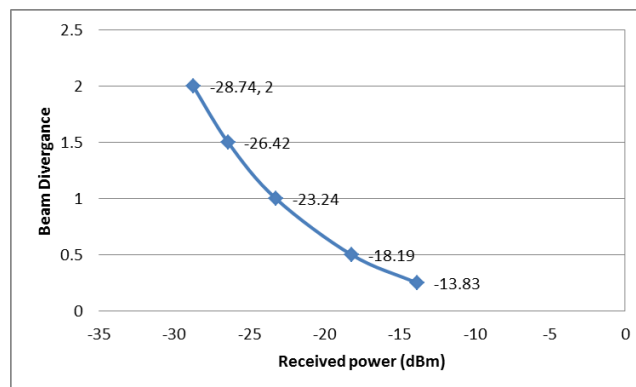
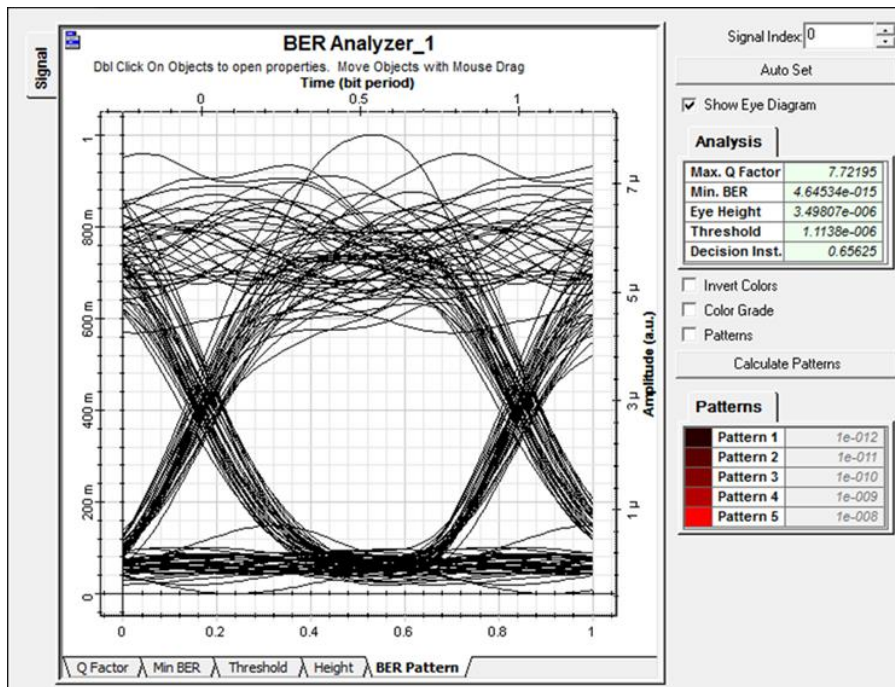
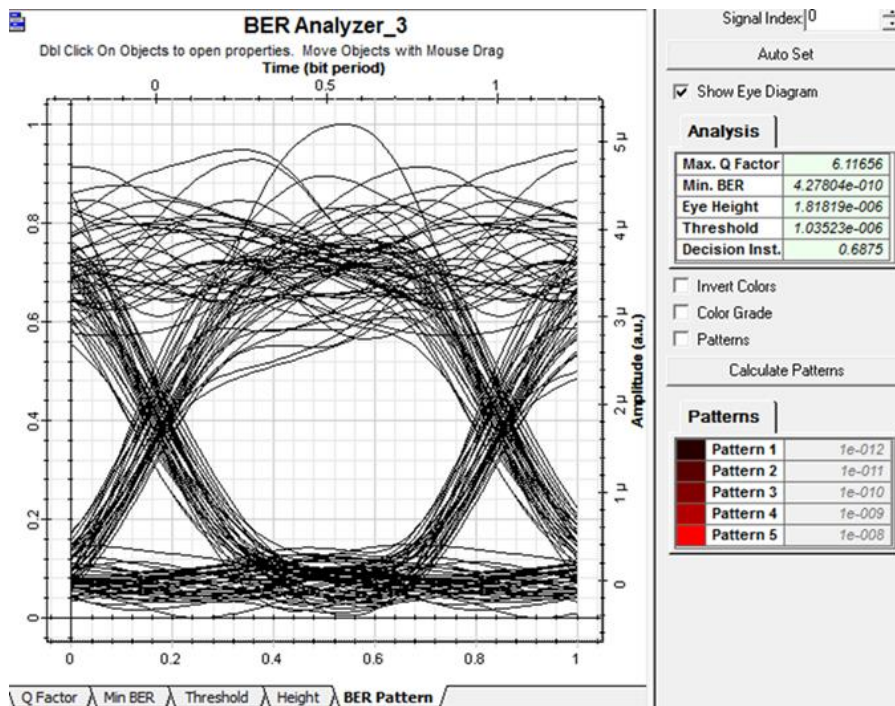

Figure 8. Beam of divergence versus received power the proposed VLC system based on LOS/ NLOS environment

VLC System performance is highly affected by measured received power and opening-eyes diagrams. Figure 9 shows the output signal as a result of a LOS and NLOS path comparison. LOS elements have wide opening eyes diagram, whereas NLOS features a flat bandwidth, but a weaker response and a smaller magnitude with closer eyes diagram. In summary, there is a significant improvement in terms of BER of 6.3×10^{-20} (Figure 9 c) due to LOS and NLOS paths' interference; the MMF plays a significant through the collecting the received optical power for the NLOS direction. Although reflections from surrounding objects have a minor effect on performance, VLC degrades with the surrounding environment. Simulation parameters are mainly based on the previously published articles [11-12].



(a) LOS at 200m with received power of -22dBm



(b) NLOS at 200m with received power of -25.43 dBm

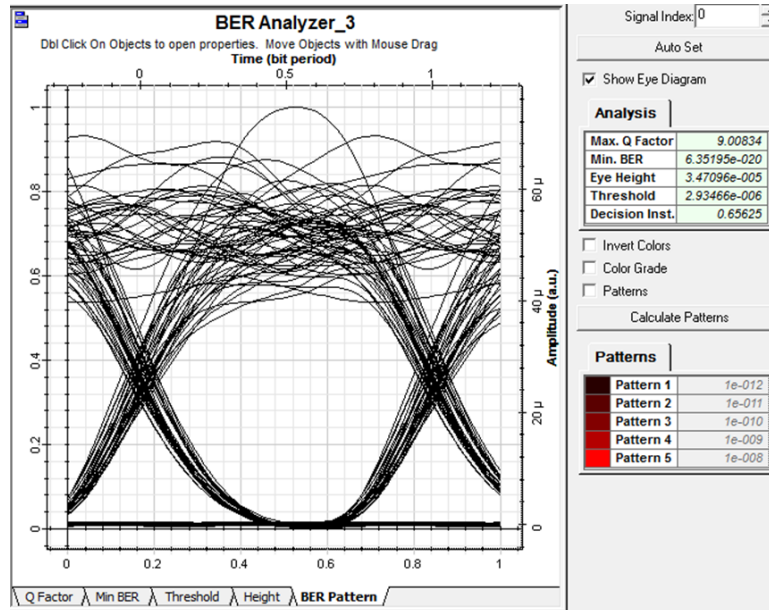

Figure 9. BER VLC system performance for a) LOS at transmission distance of 200m ; b) NLOS at transmission distance of 250m ; c) enhanced NLOS using multichannel configuration

In Table 1, the received power values for various data rates are presented. As the data rate increases, each received power value also decreases, which is due to the increasing transmission rate of the designed system. Accordingly, the proposed VLC prototype is mainly suitable for indoor environments.

Table 1. received power of multichannel NLOS and conventional NLOS as a function of transmission rate

| Transmission rate (Mbps) | Conventional NLOS (dBm) | Multichannel NLOS (dBm) |
|--------------------------|-------------------------|-------------------------|
| 150 | -19.45 | -16.23 |
| 200 | -21.23 | -19.32 |
| 250 | -23.12 | -21.34 |
| 350 | -25.54 | -23.914 |
| 400 | -27.32 | -25.34 |

Figure 10 shows the bit error rate versus the transmission distance for different approaches. With increasing distances from (1-250) m, the received power gradually increases between successive samples. It is indicated from the figure that, as the transmission range increases, the received power decreased. With the multichannel NLOS, the value of the collected power has significantly improved. For example, at 150m the power was -16dBm and -19dBm for multichannel NLSO and conventional NLOS, respectively. Further increasing the transmission range within the transceiver results in a decreasing amount of received power.

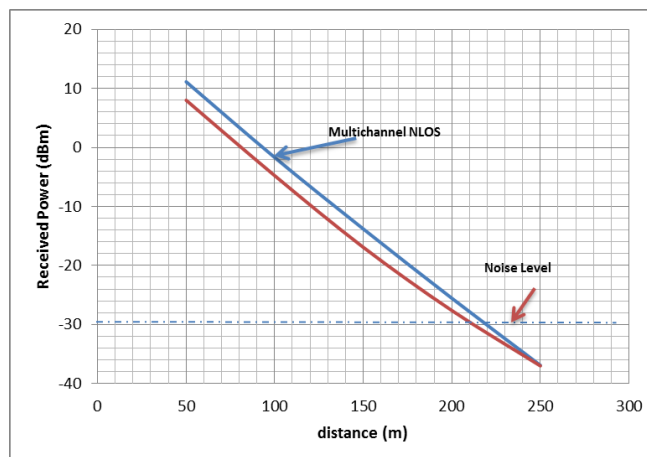

Figure 10. comparison analysis for the Received power versus transmission distance

The proposed Multi-Channel Configuration is compared as shown in Table 2 with other published work based on the quality factor (Q-factor). According to the results, even with a lower data rate of 400 Mbps, the proposed Multi-Channel Configuration can achieve this level of performance at a significant Q factor than other published results.

Table 2. VLC system comparison

| No. | System Types | Data Rate | Quality factor (Q-factor) |
|-----|--------------------------------------|-----------|---------------------------|
| 1 | Previous model based LED (Ref.#7) | 144 Mbps | 5 dB |
| 2 | Previous model based Laser (Ref.#12) | 2.5 Gbps | 10 dB |
| 4 | Proposed model based Multi-channel | 400 Mbps | 7.5 dB |

5. CONCLUSION

The VLC technology utilizes a light LED transmitter that does not cause radio frequency interference and has a large communication bandwidth, making it the type of green technology. An innovative technique based on multichannel configurations was proposed to address the main drawback of VLC's NLOS system. The VLC systems utilizing LEDs can deliver illumination and data communication simultaneously. The simulation design setup is based on an indoor VLC system using OptiSystem software. A proof of principle has been analyzed in terms of transmission distance, BER, data rate and eyes diagram under various conditions. Beside, a recent review of all types of LEDs is presented. In order to overcome the challenges associated with ambient light noise interference, Multimode fiber (MMF) is used to achieve minimal BER and higher received power.

REFERENCES

- [1] Zhao, P., & Zhao, H. (2012). Analysis of light extraction efficiency enhancement for thin-film-flip-chip InGaN quantum wells light-emitting diodes with GaN microdomes. *Optics Express*, 20(105), A765–A776.
- [2] Son, T., Shin, D. S., Mageshwari, K., Kim, K.-K., & Park, J. (2015). Improved light extraction efficiency and leakage characteristics in light-emitting diodes by nanorod arrays formed on hexagonal pits. *Materials Science in Semiconductor Processing*, 29, 380–385.
- [3] Du, C., Huang, X., Jiang, C., Pu, X., Zhao, Z., Jing, L., Hu, W., & Wang, Z. L. (2016). “Tuning carrier lifetime in InGaN/GaN LEDs via strain compensation for high speed visible light communication”. *Scientific Reports*, 6(1).
- [4] Alatawi, A. A., Holguin-Lerma, J. A., Kang, C. H., Shen, C., Subedi, R. C., Albadri, A. M., Alyamani, A. Y., Ng, T. K., & Ooi, B. S. (2018). High-power blue superluminescent diode for high CRI lighting and high-speed visible light communication. *Optics Express*, 26(20), 26355–26364.
- [5] Y. Tanaka, S. Haruyama, and M. Nakagawa, “Wireless optical transmissions with white colored LED for wireless home links,” in *Personal, Indoor and Mobile Radio Communications, 2000. PIMRC 2000. The 11th IEEE International Symposium on*, vol. 2. IEEE, 2000, pp. 1325–1329.
- [6] T. Kishi, H. Tanaka, Y. Umeda, and O. Takyu, “A high-speed LED driver that sweeps out the remaining carriers for visible light communications,” *Journal of Lightwave Technology*, vol. 32, no. 2, pp. 239–249, 2014.
- [7] B. Siddique and M. Tahir, “Joint rate-brightness control using variable rate MPPM for LED based visible light communication systems,” *IEEE Transactions on Wireless communications*, vol. 12, no. 9, pp. 4604–4611, 2013.
- [8] J. M. Kahn and J. R. Barry, “Wireless infrared communications,” *Proc. IEEE*, vol. 85, no. 2, pp. 265–298, 1997.
- [9] M. Kavehrad, “Sustainable energy-efficient wireless applications using light,” *IEEE Communications Magazine*, vol. 48, no. 12, pp. 66–73, 2010.
- [10] H. Elgala, R. Mesleh, and H. Haas, “Indoor optical wireless communication: potential and state-of-the-art,” *IEEE Communications Magazine*, vol. 49, no. 9, 2011.
- [11] Mohamad Obeed; Anas M. Salhab; Mohamed-Slim Alouini “On Optimizing VLC Networks for Downlink Multi-User Transmission: A Survey” *IEEE Communications Surveys & Tutorials* Volume: 21, Issue: 3, 2019.
- [12] Hao Ma, Ayman Mostafa, Lutz Lampe and Steve Hranilovic, “Coordinated Beamforming for Downlink Visible Light Communication Networks,” *IEEE Transactions on Communications*, DOI 10.1109/TCOMM.2018.2817222, 2018.
- [13] H. Zhang, N. Liu, K. Long, J. Cheng, V. C. M. Leung, and L. Hanzo, “Energy efficient subchannel and power allocation for the software defined heterogeneous VLC and RF networks,” *IEEE Journal on Selected Areas in Communications*, vol. PP, no. 99, pp. 1–1, 2018.
- [14] H. Ma, A. Mostafa, L. Lampe, and S. Hranilovic, “Coordinated beamforming for downlink visible light communication networks,” *IEEE Transactions on*