

Link Adaptation for Microwave Link using both MATLAB and Path-Loss Tool

Jide Julius Popoola*¹, Damian E. Okhueigbe¹, Isiaka A. Alimi^{1,2}

¹Department of Electrical and Electronics Engineering, Federal University of Technology, Akure, Nigeria

²Instituto de Telecomunicações, DETI, Universidade de Aveiro, Aveiro, Portugal

e-mail: jidejulius2001@gmail.com*; damianeee2008@yahoo.com; compeasywalus2@yahoo.com

Abstract

The inherent multipath transmission on wireless channels usually leads to signal fading which eventually degrades the system performance. In mitigating this problem, link adaptation has been identified as a promising scheme that helps in maximizing the system spectral efficiency (SE) in dispersive wireless channels. In this paper, link adaptation based on adaptive modulation and coding was used to study the performance of M-ary quadrature amplitude modulation radio system subjected to multipath fading. MATLAB® scripts and Simulink model were developed to compare the effect of wireless channel on different constellation sizes. Also, transmission link on Federal University of Technology Akure campus' path terrain was designed with the aid of path-loss® tool software in order to further analyze the effect of using different modulation formats on the system performance. The results show that, employment of link adaptation scheme offers better performance regarding the system availability and SE.

Keywords: wireless channels, multipath transmission, link adaptation, spectral efficiency, constellation sizes

1. Introduction

In recent years, radio or wireless communication system has replaced almost all wired communication systems in telecommunications. This is as a result of tremendous advantages that wireless communication systems have over the fixed-wired communication systems. Two of these major advantages are its ability to be rolled out rapidly and its mobility capability. With this shift from wired connection to wireless connection, it is obvious that an acceptable quality of service (QoS) on wireless channels can only be achieved through higher information transfer rates than the currently available rates in today's wireless system. In order to increase the current information or data transfer rates to the next level, a simple approach is to increase the allocated bandwidth. However, this approach is practically infeasible due to the fact that radio spectrum is extremely scarce due to proliferation of wireless services, devices and application. In addition, the growth in information transmission via wireless technologies has led to increase in both the demand for the radio spectrum and consumption of more bandwidth for services such as video-on-demand, high-speed Internet access, video conferences and applications with multimedia contents.

Furthermore, the fact that wireless channels is currently the most commonly used channel for signal transmission, observations show that signals transmitted over wireless channels are often being impaired due to undesirable effects on wireless channels [1]. This makes wireless channels to be characterized by multipath transmission of signal. Thus, results in the variation of the signal strength which leads to signal fading when replicas are combined at the receiver (Rx). With signal fading, there is high degradation in the link carrier-to-noise ratio (CNR) as well as high bit error rate (BER) in the radio link [2].

These detrimental effects of signal fading call for an appropriate measure that can mitigate it. Different measures such as space diversity [3-5], automatic transmit power control (ATPC) [6], adaptive equalization, multilevel coded modulation (MLCM) [7,8], forward error correction (FEC), and cross-polarization interference cancellers (XPICs) [9] have been proposed in the literature to address the challenges of signal fading. However, aiming at the inherent capacity of wireless channel, it is obvious that technology which adapt and adjust transmission parameters in real-time based on the link quality will be the appropriate solution to both the problems of channel impairments and bandwidth in wireless communication. Thus, the primary objective of the study presented in this paper is to investigate the effectiveness of

adaptive modulation scheme in enhancing both the transmission rates and SE in wireless communication.

For sequential and logical presentation of the study presented in this paper, the remaining parts of this paper are organized as follows. Section 2 presents a brief overview on link adaptation scheme and SE. Section 3 focuses on methodology involved in carrying out the study with emphasis on different simulation and link design parameters using FUTA as case study. In Section 4, the results of the study are presented and discussed while the conclusion is presented in Section 5.

2. Link Adaptation

Link adaptation, also known as adaptive modulation (AM) or adaptive modulation and coding (AMC), is a technique employed in wireless communication system to denote the matching of the modulation coding as well as the signal and protocol parameters to the conditions on the radio link. Thus, the process of link adaptation is a dynamic technique that brings about changes in both the signal and protocol parameters as the link conditions change. According to [10], link adaptation is a powerful technique for improving the SE in wireless transmission over fading channels. It works by exploiting the channel state information (CSI) at the transmitter. This capability enhances its performance when compared with systems that do not exploit channel knowledge at the transmitting end.

Link adaptation based on AMC as reported in [11] is one of the promising adaptive schemes to counteract fading and enhance the performance of wireless system. It is an efficient link adaptation technique in which transmission parameters such as modulation format, code-rate, and power are regulated in accordance with the CSI. The concept of the scheme is based on monitoring the channel variations in order to determine the error rate at the receiver (Rx). When the error rate increases, the Rx sends feedback information about the nature of the CSI to the transmitter (Tx). Consequently, the Tx dynamically changes the modulation and coding formats in order to achieve better throughput by transmitting higher information rates in good CSI conditions. However, in poor CSI conditions, the Tx automatically shifts its transmission to a more robust but less efficient modulation and coding formats in response to the channel degradation [12]. In essence, in a good CSI condition, highest sustainable data rate is transmitted; whereas, when the CSI is poor, lower data rate is transmitted [13]. The activities involve in both the Tx and Rx in an AMC scheme using an additive white Gaussian noise (AWGN) channel is shown in Fig. 1. Fig. 1 shows the interaction involves in both the Tx and Rx in order to achieve the desired SE and high transmission that AMC scheme offers in wireless communication system [14].

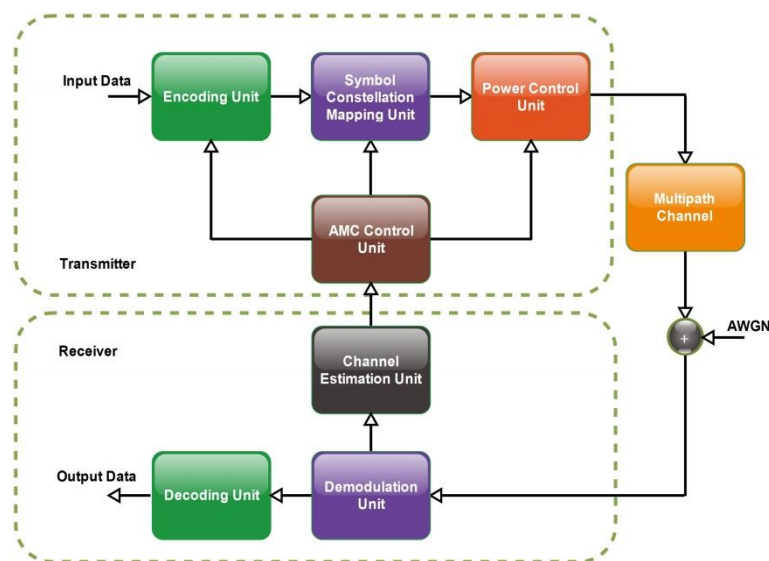

Figure 1. Block Diagram of Adaptive Modulation and Coding Scheme (Adapted from [13])

Spectral efficiency, SE, by simple definition is the amount of information or data that can be transmitted over a given bandwidth in a specific communication system. It is also defined as the ratio of the data rate to the bandwidth of the modulation signal. Thus, SE means getting more bits per hertz and being expressed in bps/Hz. It is the optimized use of the spectrum such that the maximum amount of data can be transmitted with minima transmission errors. It is one of the major factors in the design of wireless communication system [15]. As reported in [15], frequency re-use is one of the ways of achieving SE. However, according to [16-18], application of frequency re-use usually introduces unavoidable co-channel interference in wireless communication system. However, as reported by [15], another technique of increasing spectral efficiency in wireless communication systems is the application of multilevel or M-ary quadrature amplitude modulation (M-QAM) schemes. This is because M-QAM increases the link SE by sending multiple bits per symbol as reported in [15]. QAM is able to achieve this because the two carrier waves in it, $(\cos 2\pi f_c t)$ and $(\sin 2\pi f_c t)$, which are out of phase with each other by 90° called quadrature carriers or quadrature components are algebraically summed [19]. The algebraic sum of these modulated waves gives a single signal to be transmitted, containing the in-phase (I) and quadrature (Q) information [20]. Thus, the resulting M-QAM signal is defined mathematically in [19] as;

$$\begin{aligned} s(t) &= I(t) \cdot \cos(2\pi f_c t) + Q(t) \cdot \sin(2\pi f_c t) \\ &= A_m^I \cdot g(t) \cdot \cos(2\pi f_c t) + A_m^Q \cdot g(t) \cdot \sin(2\pi f_c t) \quad m=1,2,3,\dots,M \end{aligned} \quad (1)$$

where $I(t)$ and $Q(t)$ are the modulating signals, A_m^I and A_m^Q are the sets of the amplitude levels for the in-phase and quadrature phase respectively, and $g(t)$ is the real valued signal pulse, whose shape influences the spectrum of the transmitted signal .

In digital formats of M-QAM, two or more bits are usually grouped together to form symbols and one of M possible signals is transmitted during each symbol period. Normally, the number of possible signals is expressed mathematically in [19] as;

$$M = 2^n \quad (2)$$

where n is an integer. Therefore, possible M-QAMs are: 4-QAM, 8-QAM, 16-QAM, 32-QAM, 64-QAM, and so on. The number of 4, 8, 16, 32 and 64 is corresponding to 2^2 , 2^3 , 2^4 , 2^5 and 2^6 in which the superscript number 2, 3, 4, 5 or 6 is the bits per symbol respectively. Similarly, survey literature reviews that SE achievable is considerably high when a low order constellation such as quaternary phase shift keying (QPSK) is employed in wireless communication system. Mathematically, QPSK signal can be represented as:

$$s(t) = A_c \cos\left(2\pi f_c t + (i-1)\frac{\pi}{2}\right) \quad i=1,2,3,4 \quad (3)$$

Using trigonometric identity, $\cos(x+y) = \cos x \cos y - \sin x \sin y$, (3) can be re-written as:

$$s(t) = A_c \cos(2\pi f_c t) \cos\left\{(i-1)\frac{\pi}{2}\right\} - A_c \sin(2\pi f_c t) \sin\left\{(i-1)\frac{\pi}{2}\right\} \quad i=1,2,3,4 \quad (4)$$

In microwave radio systems, adaptive modulation is employed for point to point digital communication in order to offer better capacity to the user. This is based on the CSI feedback that enables dynamic radio link adaption. An example of adaptive technique being implemented in the microwave radio links to combat fading is ATPC which is also known as power diversity

[6]. Conceptually, a threshold power is set to achieve a given BER under good channel conditions. The Tx power can be adjusted (increased or decreased) dynamically according to the link condition. However, the increase in power when the CSI is poor should not exceed the set threshold value so as to prevent co-channel interference (CCI) [6,22]. Moreover, an alternative approach of achieving a desired QoS is by the use of adaptive modulation scheme in which the power and modulation level can be dynamically altered in order to regulate the link ability to conform to the set transmission conditions [22]. This simulation and link design carried out in achieving the objectives of the study presented in this paper is presented in the next section.

3. Methodology

In this section, the methodology involved in carrying out this study is presented. This section presents the simulation, design, and analysis of the adaptive modulation system for the microwave transmission link. The simulation and modeling are implemented in MATLAB[®]/Simulink[®]. The Simulink for the microwave transmission link is shown in Fig. 2. Furthermore, the design of transmission link on FUTA path terrain is achieved with the aid of PATHLOSS[®] 4.0 simulation tool. This is done using factors and parameters such as the geographical coordinates of the terrain, path profile from Shuttle Radar Topography Mission database, the International Telecommunication Union (ITU) recognized transmit and receive frequency, a standard Microwave Networks radio model, AMT/07/16E1/14M, an antenna code model, a traffic code of 16E1-16QAM and 16E1-QPSK with horizontal polarization for worst condition in the path design modules of the program.

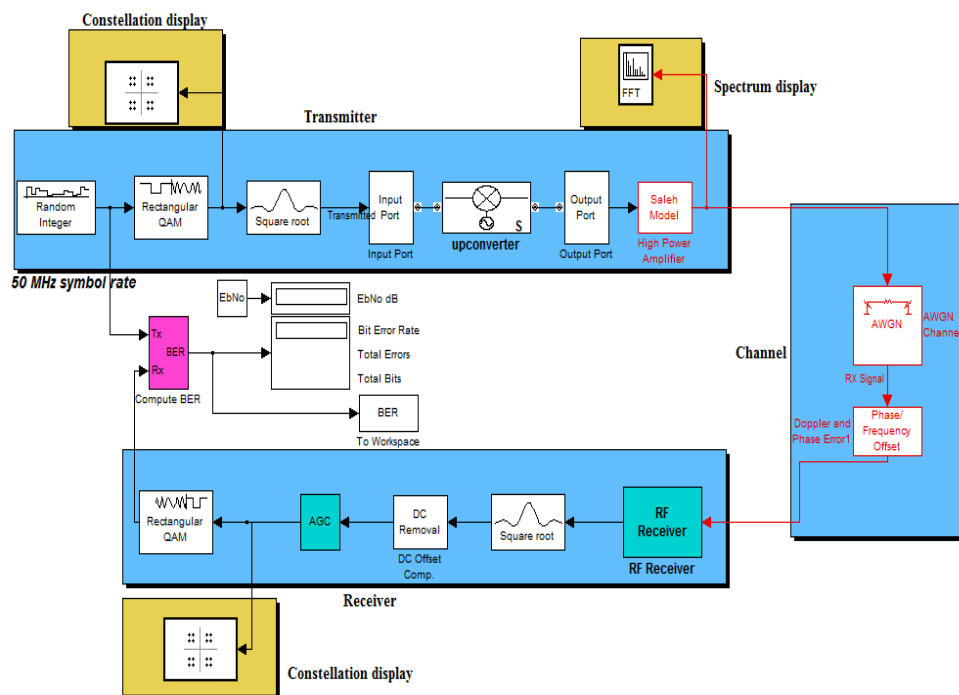

Figure 2. Simulink for Microwave Transmission Link Model

4. Results and Discussion

This section is divided into two subsections. The first subsection presents the effect of link adaptation or adaptive modulation on FUTA wireless link. This was done by presenting the results of MATLAB[®] scripts and Simulink model that were developed to compare the effect of wireless channel on different constellation sizes. On the other hand, the second subsection presents results of transmission link on FUTA path terrain that was designed with the aid of

Pathloss® tool application software. The results obtained and the discussions are presented as follows in the following sub-sections.

4.1. Effect of Link Adaptation on different Constellation Sizes

This subsection presents results of the link adaptation on both the data or information transmission rate and the SE. Simulink model was employed in varying the constellation sizes and SNR in order to study the effects of adaptive modulation by varying the constellation parameters on the microwave transmission system. In the analysis, the effect of additive white Gaussian noise (AWGN) is observed at a symbol rate of 50 MHz and transmits frequency of 5.29 GHz. The BER generated and number of bits received for different M-ary quadrature amplitude modulation (M-QAM) and SNR are illustrated in Table 1. The results of the study show that out of all constellation sizes considered, 16-QAM has the least BER while 256-QAM has the highest BER. Moreover, for all constellation sizes considered, the number of bits received increase with increase in SNR on the AWGN channel employed. This shows that with the adaptive modulation and coding more bits are transmitted with increase in SNR. The result of the study thus shows that with adaption of link adaptation on wireless link results in more data or information transmission and high SE.

Table 1. BER Values and Number of Bits at Different SNR and M-QAM

SNR	MODULATION SCHEMES									
	16-QAM		32-QAM		64-QAM		128-QAM		256-QAM	
	BER	No of Bit	BER	No of Bit	BER	No of Bit	BER	No of Bit	BER	No of Bit
0	0.0208	1504	0.125	920	0.1495	1104	0.1929	840	0.2411	448
3	0.0208	5088	0.0673	1560	0.0847	1488	0.0286	840	0.1563	960
6	0.0034	29664	0.0212	4760	0.051	2256	0.0947	1288	0.0505	960
9	0.0001	883936	0.0036	28120	0.0162	6480	0.0495	3184	0.0734	1472
12	1.9E-07	10000020	0.0001	818200	0.0032	31440	0.0146	7112	0.0382	3008

Furthermore, MATLAB® scripts were used to analyse the relationship between SNR and the BER for the five M-QAM schemes considered. The result obtained, as shown in Fig. 3, shows that increase in the constellation size led to corresponding increase in the BER. Therefore, to maintain high transmission quality in a given channel condition, an effective modulation format was employed. For instance, to achieve a BER of 10^{-4} , with M=16, 32, and 128, about 13 dB, 15 dB, and 20 dB are required, respectively. This illustrates that, reducing the constellation size is a good option for reducing the effect of impairments caused by both fading and noise.

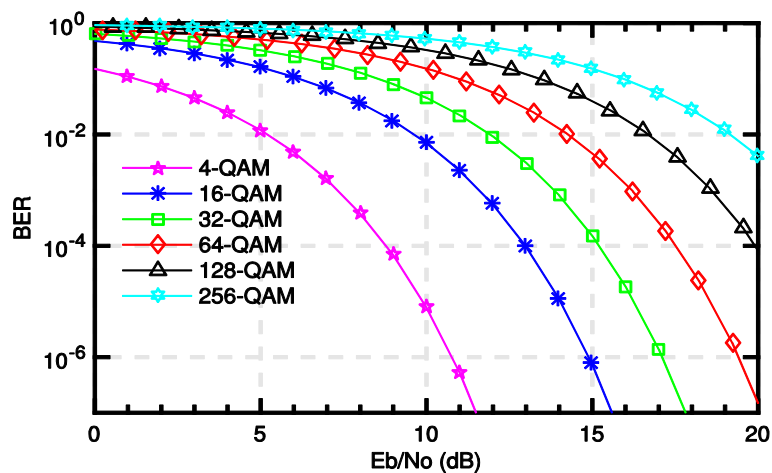

Figure 3. Plot of BER against SNR for Different Constellation Sizes

In an attempt to study the implementation of adaptive modulation in microwave radio system, threshold levels were set in the scripts to achieve a system BER that is less than 10^{-4} for each modulation formats. This allows an automatic switching between modulation formats based on the SNR. In general, for fixed radio-link, modulation formats such as 64, 128, 256, and 512-QAM are normally employed whereas low-order constellations such as 4, 16, and 32-QAM, are implemented in adaptive links [23].

Furthermore, in evaluating the performance of the adaptive modulation, the switching results for 16-QAM and 32-QAM were compared. The compared results include the scatter plots, power spectral density, and in-phase components of the eye diagrams of the analysed signal. Also, the results of the channel impairment effects on the received signal that lead to the switching for the two modulation formats were presented for comparison. The scatter plot and the eye diagrams for the transmitted and received signal for 16-QAM and 32-QAM are shown in Fig. 4 and Fig. 5 respectively for the switching. The eye diagrams confirm that there is significant difference between the received signal and the transmitted signal. The difference is due to the channel impairments on the signal which make the eye to be constrained. Also, the power spectral density of transmit and received signal for 16-QAM and 32-QAM are shown in Fig. 6 and Fig. 7, respectively. The effect of channel impairments is clearly shown on each received signal with 16-QAM having high power efficiency compared with the 32-QAM.

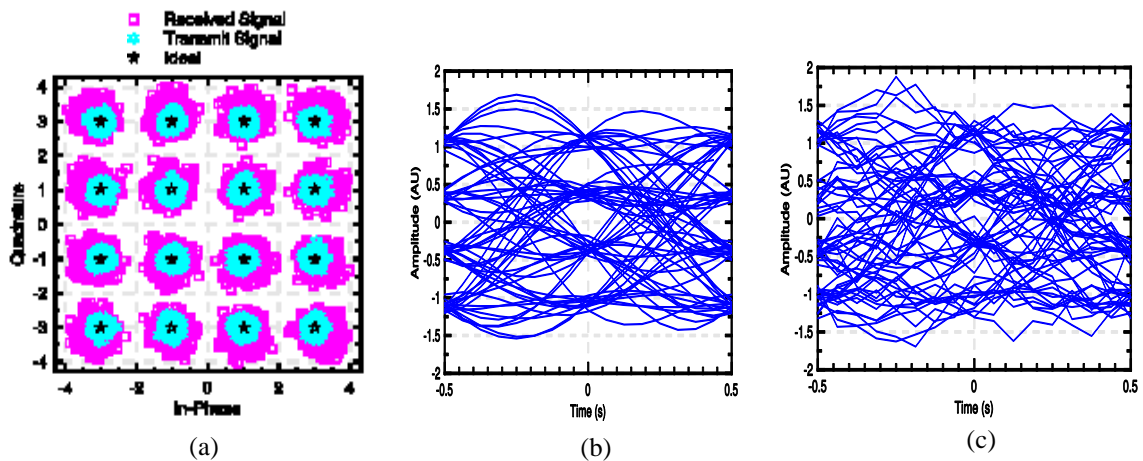

Figure 4. Plot for 16-QAM (a) scatter plot (b) eye diagram for the transmit signal (c) eye diagram for the received signal

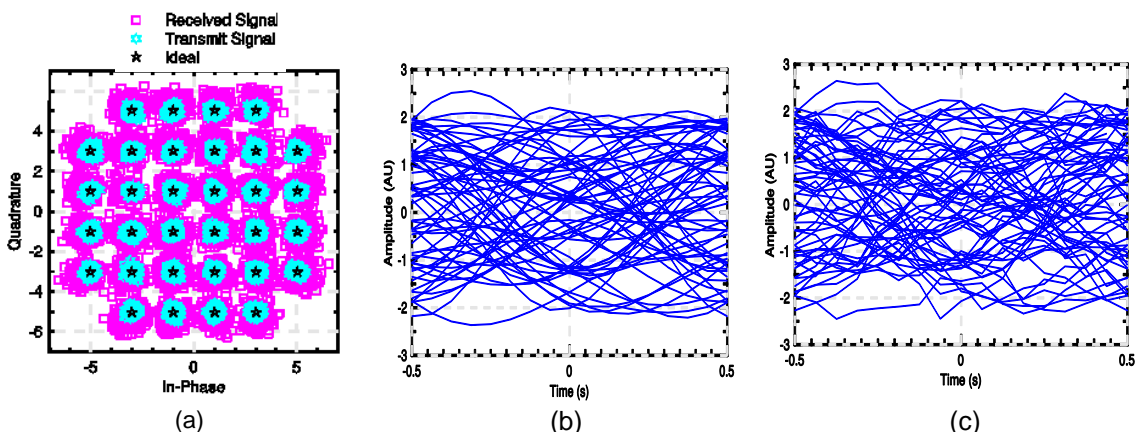

Figure 5. Plot for 32-QAM (a) scatter plot (b) eye diagram for the transmit signal (c) eye diagram for the received signal

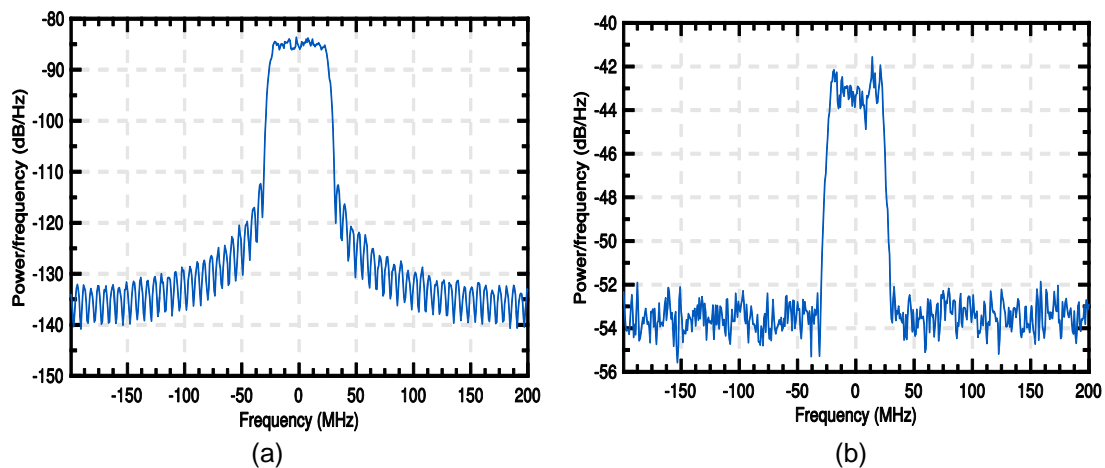

Figure 6. Power Spectral Density of (a) Transmit and (b) received signal for 16-QAM.

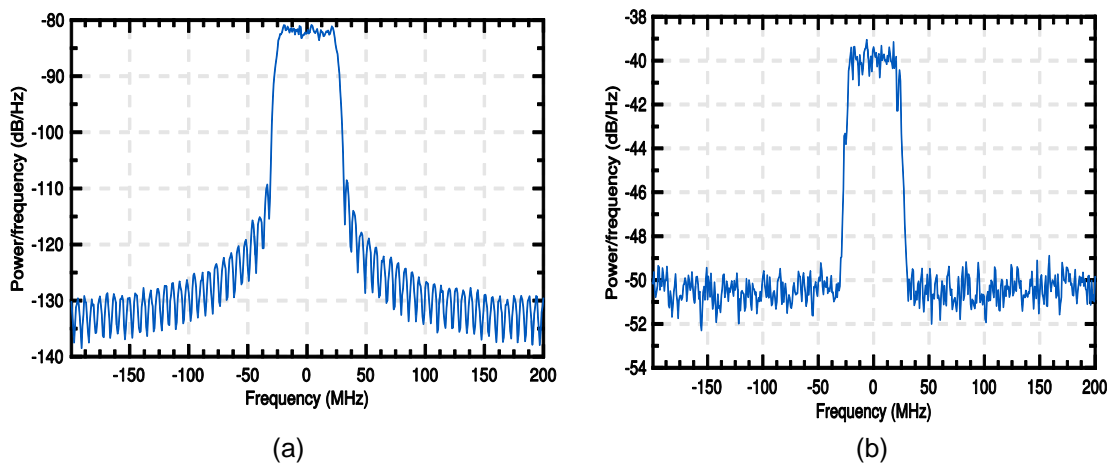

Figure 7. Power Spectral Density of (a) Transmit and (b) received signal for 32-QAM.

4.2. Performance of the Transmission Link Budget

This subsection presents results of design of link budget with respect to the microwave transmission link being designed for Site 1 and Site 2. The effects of using modulation schemes such as 16E1- QPSK and 16E1-16QAM on the link budget are analysed. Table 2 and Table 3 show the link budget designed for 16E1-16-QAM and 16E1-QPSK modulation schemes respectively. The effective isotropic radiated powers (EIRPs) of 51.27dBm and 55.27dBm are obtained for 16-QAM and QPSK modulation schemes respectively. This shows that, lesser power is transmitted with 16-QAM so as to meet the transmit mask criterion. Moreover, the fade margins of 44.14dBm and 52.14dBm are achieved for 16-QAM and QPSK modulation schemes, respectively. This result indicates that, the link availability is higher when QPSK is employed. This is due to the fact that the percentage of link availability increases with the fade margin value.

Table 2. Designed Link Budget of 16E1-16QAM Modulation Scheme

Parameter	Site 1	Site 2
Elevation (m)	371.00	373.00
Latitude	07 18 00.00 N	07 18 00.00 N
Longitude	005 08 00.00 E	005 09 00.00 E
True azimuth (°)	63.40	243.40
Vertical angle (°)	-0.04	0.02
Antenna model	VHP4-71	VHP4-71
Antenna height (m)	22.32	19.21
Antenna gain (dBi)	36.40	36.40
TX line type	EWP77	EWP77
TX line length (m)	100.00	100.00
TX line unit loss (dB/100 m)	6.13	6.13
TX line loss (dB)	6.13	6.13
Frequency (MHz)	7200.00	7200.00
Polarization	Horizontal	Horizontal
Path length (km)	2.06	2.06
Free space loss (dB)	115.88	115.88
Atmospheric Absorption loss (dB)	0.02	0.02
Net path loss (dB)	55.36	55.36
Radio model	AMT/07/16E1/14M	AMT/07/16E1/14M
TX power (watts)	0.13	0.13
TX power (dBm)	21.00	21.00
EIRP (dBm)	51.27	51.27
Emission designator	14MOD7W	14MOD7W
TX Channels	4h 7310.0000H 41 7149.0000H	4h 7310.0000H 41 7310.0000H
RX threshold criteria	BER 10-6	BER 10-6
RX threshold level (dBm)	-78.50	-78.50
RX signal (dBm)	-34.36	-34.36
Thermal fade margin (dB)	44.14	44.14
Dispersive fade margin (dB)	52.00	52.00
Dispersive fade occurrence factor	1.00	1.00
Effective fade margin (dB)	43.48	43.48
Geoclimatic factor	1.98E-04	1.98E-04
Path inclination (mr)	0.54	0.54
Fade occurrence factor (Po)	8.46E-05	8.46E-05
Average annual temperature (°C)	24.00	24.00
Worst month - multipath (%)	100.00000	100.00000
(sec)	9.98E-03	9.98E-03
Annual - multipath (%)	100.00000	100.00000
(sec)	0.04	0.04
(% - sec)	100.00000 – 0.09	100.00000 – 0.09
Rain region	ITU Region F	ITU Region F
0.01% rain rate (min/hr)	28.00	28.00
Flat fade margin – rain (dB)	44.14	44.14
Rain rate (mm/hr)	8268.82	8268.82
Rain attenuation (dB)	44.14	44.14
Annual rain (%-sec)	100.00000 – 0.00	100.00000 – 0.00
Annual multipath + rain (%-sec)	100.00000 – 0.09	100.00000 – 0.09

futa sites_16QAM.p14

Reliability Method – ITU-R P.530-7/8

Rain – ITU-R P530-7

Table 3. Designed Link Budget of 16E1-QPSK Modulation Scheme

Parameter	Site 1	Site 2
Elevation (m)	371.00	373.00
Latitude	07 18 00.00 N	07 18 00.00 N
Longitude	005 08 00.00 E	005 09 00.00 E
True azimuth ($^{\circ}$)	63.40	243.40
Vertical angle ($^{\circ}$)	-0.04	0.02
Antenna model	VHP4-71	VHP4-71
Antenna height (m)	22.32	19.21
Antenna gain (dBi)	36.40	36.40
TX line type	EWP77	EWP77
TX line length (m)	100.00	100.00
TX line unit loss (dB/100 m)	6.13	6.13
TX line loss (dB)	6.13	6.13
Frequency (MHz)	7200.00	7200.00
Polarization	Horizontal	Horizontal
Path length (km)	2.06	2.06
Free space loss (dB)	115.88	115.88
Atmospheric Absorption loss (dB)	0.02	0.02
Net path loss (dB)	55.36	55.36
Radio model	AMT/07/16E1/28M	AMT/07/16E1/28M
TX power (watts)	0.32	0.32
TX power (dBm)	25.00	25.00
EIRP (dBm)	55.27	55.27
Emission designator	28MOG7W	28MOG7W
TX Channels	4h 7310.0000H 41 7149.0000H	4h 7310.0000H 41 7310.0000H
RX threshold criteria	BER 10-6	BER 10-6
RX threshold level (dBm)	-82.50	-82.50
RX signal (dBm)	-30.36	-30.36
Thermal fade margin (dB)	52.14	52.14
Dispersive fade margin (dB)	49.00	49.00
Dispersive fade occurrence factor	1.00	1.00
Effective fade margin (dB)	47.28	47.28
Geoclimatic factor	1.98E-04	1.98E-04
Path inclination (mr)	0.54	0.54
Fade occurrence factor (Po)	8.46E-05	8.46E-05
Average annual temperature ($^{\circ}$ C)	24.00	24.00
Worst month - multipath (%)	100.00000	100.00000
(sec)	4.16E-03	4.16E-03
Annual - multipath (%)	100.00000	100.00000
(sec)	0.02	0.02
(% - sec)	100.00000 – 0.04	100.00000 – 0.04
Rain region	ITU Region F	ITU Region F
0.01% rain rate (min/hr)	28.00	28.00
Flat fade margin – rain (dB)	52.14	52.14
Rain rate (mm/hr)	9844.15	9844.15
Rain attenuation (dB)	52.14	52.14
Annual rain (%-sec)	100.00000 – 0.00	100.00000 – 0.00
Annual multipath + rain (%-sec)	100.00000 – 0.04	100.00000 – 0.04

futa sites_QPSK.p14

Reliability Method – ITU-R P.530-7/8

Rain – ITU-R P530-7

5. Conclusion

This paper presents microwave transmission model employed in simulating the effects of different constellation sizes and the SNR on the implementation of adaptive modulation scheme. The symbol rate of 50 MHz and transmit frequency of 5.29 GHz are employed in the analysis. In addition, the paper presents designs for transmission link on FUTA path terrain in which the effect of using different modulation schemes are analyzed. The results obtained show that implementation of adaptive modulation scheme offers better performance with regard to system availability as well as spectral efficiency. Furthermore, the overall result of this study has shown clearly that adaptive modulation scheme as a technology that adapts and adjusts transmission parameters in real-time based on the link quality is the appropriate solution to both the problems of channel impairments and bandwidth in wireless communication.

References

- [1] Popoola, J.J. Computer Simulation of Hata's Equation for Signal Fading Mitigation. *Pacific Journal of Science and Technology*. 2009; 10(2): 462-470.
- [2] Hole, K.J., Holm, H., Oien, G.E. Adaptive Multidimensional Coded Modulation over Flat Fading Channels. *IEEE Journal on Selected Areas in Communications*. 2000; 18(7): 1153-1158.
- [3] Dinc, E., Akan, O.B. Fading Correlation Analysis in MIMO-OFDM Troposcatter Communications: Space, Frequency, Angle and Space-Frequency Diversity. *IEEE Transactions on Communications*. 2015; 63(2): 476-486.
- [4] Renzo, M.D., Haas, H. Space Shift Keying (SSK) MIMO over Correlated Rician Fading Channels: Performance Analysis and a New Method for Transmit-Diversity. *IEEE Transactions on Communications*. 2011; 59(1): 116-129.
- [5] Zhang, Y.Y., Yu, H.Y., Zhang, J.K., Zhu, Y.J., Wang, J.L., Wang, T. *Full Large-Scale Diversity Space Codes for MIMO Optical Wireless Communications*. IEEE International Symposium on Information Theory (ISIT), Hong Kong, 2015; 1671-1675.
- [6] Morelos-Zaragoza, R.H., Suh, K.W., Lee, J.H. *Automatic Transmit Power Control of a Digital Fixed Wireless Link with Co-Channel Interference*, 2nd International Conference on Communications and Networking. Shanghai, 2007; 1178-1184.
- [7] Farhoudi, R., Rusch, L.A. Multi-Level Coded Modulation for 16-ary Constellations in Presence of Phase Noise. *Journal of Lightwave Technology*, 2014; 32(6): 1159-1167.
- [8] Beygi, L., Agrell, E., Karlsson, M. On the Dimensionality of Multilevel Coded Modulation in the High SNR Regime. *IEEE Communications Letters*. 2010; 14(11): 1056-1058.
- [9] Proença, H., Carvalho, N.B. *Cross-Polarization Interference Cancellation (XPIC) Performance in Presence of Non-Linear Effects*. Workshop on Integrated Nonlinear Microwave and Millimeter-Wave Circuits (INMMIC), Goteborg, 2010; 93-96
- [10] Falahati, S., Svensson, A., Ekman, T., Sternad, M. Adaptive Modulation Systems For Predicted Wireless Channels, *IEEE Transactions on communication*, 2004; 52(2): 307-316.
- [11] Tan, P.H., Wu, Y., Sun, S. Link adaptation based on adaptive modulation and coding for multiple-antenna OFDM. *IEEE Journal on Selected Areas in Communications*. 2008. 26(8): 1599-1606.
- [12] Salih, S.H.O., Saliman, M.M.A. *Implementation of Adaptive Modulation and Coding Techniques using Matlab*. Proceedings ELMAR, Zadar, 2011; 137-139.
- [13] Shami, A., Maier, M., Assi, C. *Broadband Access Networks: Technologies and Deployments*, Springer US, 2010, 379 pages
- [14] Reddy, B.S.K., Lakshmi, B. *Adaptive Modulation and Coding for Mobile-WiMAX using SDR in GNU Radio*. International Conference on Circuits, Systems, Communication and Information Technology Applications (CSCITA), Mumbai, 2014; 173-178.
- [15] Bao, L., Hansryd, J., Danielson, T., Sandin, G., Noser, U. *Field Trial On Adaptive Modulation Of Microwave Communication Link At 6.8 GHz*. 9th European Conference on Antennas and Propagation (EuCAP), Lisbon, 2015; 1-5.
- [16] Chinnici, S., Decanis, C. *Channel Coding And Carrier Recovery For Adaptive Modulation Microwave Radio Links*. 5th IEEE Mediterranean Electrotechnical Conference, Valletta, 2010; 6-11 .
- [17] Ekpenyong, M.E., Isabona, J. *Improving Spectral Efficiency of Spread Spectrum Systems under Peak Load Network Conditions*. 6th International Conference on Systems and Networks Communications (ICSNC), Barcelona, 2011; 1-8.
- [18] Nagata, Y., Akaiwa, Y. Analysis for Spectrum Efficiency in Single Cell Trunked and Cellular Mobile Radio. *IEEE Transactions on Vehicular Technology*, 2006, 36(3): 100-113.
- [19] Yao, Y., Sheikh, A. Investigations in Co-Channel Interference in Microcellular Mobile Radio Systems. *IEEE Transactions on Vehicular Technology*. 2002; 41(2): 14-123.
- [20] Prasad, R. Kegel, A. Improved Assessment of Interference Limits in Cellular Radio Performance. *IEEE Transactions on Vehicular Technology*, 2002; 40(2): 412-419.
- [21] Popoola, J.J. Sensing and Detection of a Primary Radio Signal in a Cognitive Radio Environment Using Modulation Identification Technique. PhD Thesis. Johannesburg, University of the Witwatersrand.
Online[Available]: <http://mobile.wiredspace.wits.ac.za/handle/10539/11600>. Accessed on 23 August 2016.

-
- [22] Hannan, M.A., Islam M., Samad, S.A., Hussain A. QAM in Software Defined Radio for Vehicle Safety Application. *Australian Journal of Basic and Applied Sciences*, 2010; 4(10): 4904-4909.
- [23] Barbieri, A., Fertoni, D., Colavolpe, G. Time-Frequency Packing for Linear Modulations: Spectral Efficiency and Practical Detection Schemes. *IEEE Transactions on Communications*, 2009; 57(10): 2951-2959.